

KIENE

DIESEL ACCESSORIES, INC.

INDICATOR VALVE ACCESSORIES

INDICATOR VALVE CAPS

Damaged or dirty indicator valve threads make measuring cylinder pressures on a hot engine difficult and time consuming. Keep those threads ready to go with **KIENE** "PRO-TEK-TOR" and "POS-I-SEAL" indicator valve caps.

ORDERING INFORMATION:

<u>Part No.</u>	<u>Description</u>
AX-17	PRO-TEK-TOR Cap with Lanyard
AX-17A	POS-I-SEAL Cap with Lanyard
AX-17AB	POS-I-SEAL Cap, 316SS Plug, with Lanyard
AX-17B	PRO-TEK-TOR Cap (316SS) with Lanyard
AX-22	Discontinued. Replaced by AX-17.
AX-23	Discontinued. Replaced by AX-17A.
AX-55	PRO-TEK-TOR-type Cap with Integral Heat Shield



Handy Lanyard—now included with all **KIENE** valve caps.

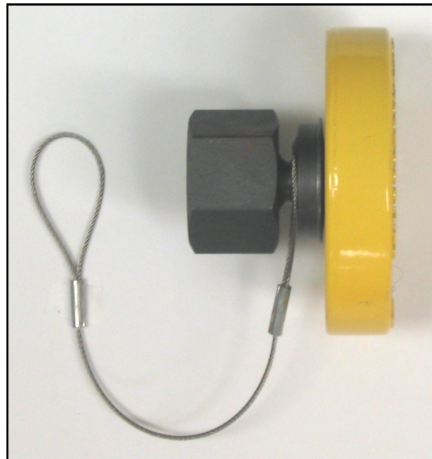

AX-55 Valve Cap with Heat Shield

Plastic heat shield reduces the possibility of accidentally touching a hot valve surface.

Improved plug design will not stick in valve socket.

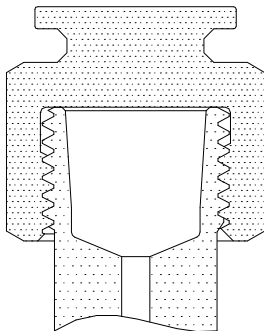

AX-17 PRO-TEK-TOR Cap protects the indicator connection from damage and dirt accumulation.

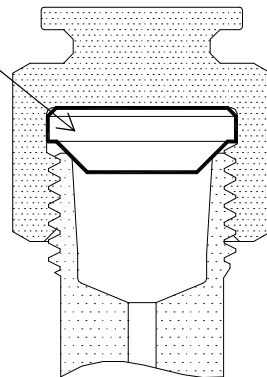

AX-17A POS-I-SEAL Cap protects and seals the indicator connection.

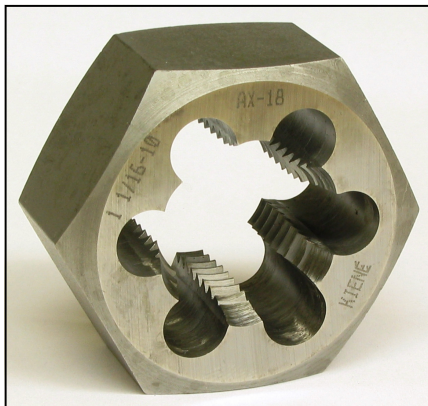

AX-18 NU-THRED DIE

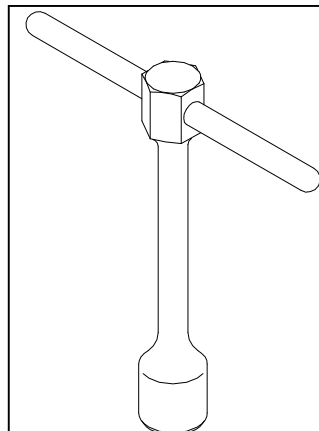

AX-19 T-HANDLE WRENCH

AX-18 NU-THRED DIE

For dressing or cleaning damaged or corroded indicator threads used on most indicator valves and adapters. The carbon steel NU-THRED DIE is hexagonal-shaped, for convenient hand operation. The NU-THRED DIE is 1-1/8" across the flats and features six thread faces (1 1/16"-10 Whitworth and 1" thread width).

AX-19 T-HANDLE WRENCH

The 5/8" integral socket, T-handle wrench is recommended for opening and closing all V-line indicator valves, prevents over-tightening of valve stem.